

...	DRAWING NAME	NO.	REV.	ISSUED
SITE PLANS				
	LOCATION SCHEME	A1-01		<input type="checkbox"/>
	SITE PLAN	A1-03		<input type="checkbox"/>
	LANDSCAPE PLAN	A1-04		<input type="checkbox"/>
PLANS				
	GROUND FLOOR & ROOF PLAN	A2-01		<input type="checkbox"/>



SITE CONTEXT

SITE LOCATION



LOCAL GOVERNMENT: SHIRE OF DERBY WEST KIMBERLEY

GENERAL NOTES:

- ALL DRAWINGS SHALL BE READ IN CONJUNCTION WITH ALL OTHER CONSULTANTS DRAWINGS AND SPECIFICATIONS.
- REFER ANY DISCREPANCIES TO ARCHITECT BEFORE PROCEEDING WITH THE WORK.
- FIGURED DIMENSIONS SHALL TAKE PRECEDENCE OVER SCALED MEASUREMENTS.
- CHECK AND CONFIRM EXISTING LEVELS AND DIMENSIONS ON SITE PRIOR TO THE COMMENCEMENT OF ANY WORK.
- THIS DRAWING IS PROTECTED BY AUSTRALIAN AND INTERNATIONAL COPYRIGHT LAW.
- EXISTING PLAN HAS BEEN DRAWN FROM SURVEY INFORMATION PROVIDED.
- EXISTING SERVICES POINTS TO BE VERIFIED ON-SITE - LOCATIONS SHOWN ON THESE PLANS ARE INDICATIVE ONLY DO NOT SCALE DIMENSIONS FROM DRAWINGS.

REV	NOTE	DATE	LAYOUT TITLE:	PROJECT STATUS:	SCALE:
A	DEVELOPMENT APPLICATION	01-09-2025	LOCATION SCHEME	DEVELOPMENT APPLICATION REV-03	N.T.S. @ A3
B	DEVELOPMENT APPLICATION REV-01	19-11-2025			DRAWN BY:
C	DEVELOPMENT APPLICATION REV-02	10-12-2025			PG
D	ROOF AND SLAB ENGINEERING	03-02-2026			
E	DEVELOPMENT APPLICATION REV-03	11-02-2026			

PROJECT CLIENT:	PROJECT NO:
PROJECT NAME 203 EMANUEL WAY FITZROY CROSSING WA 6765 LEAMY CONSTRUCTIONS	M25-429
DRAWING NO:	A1-01

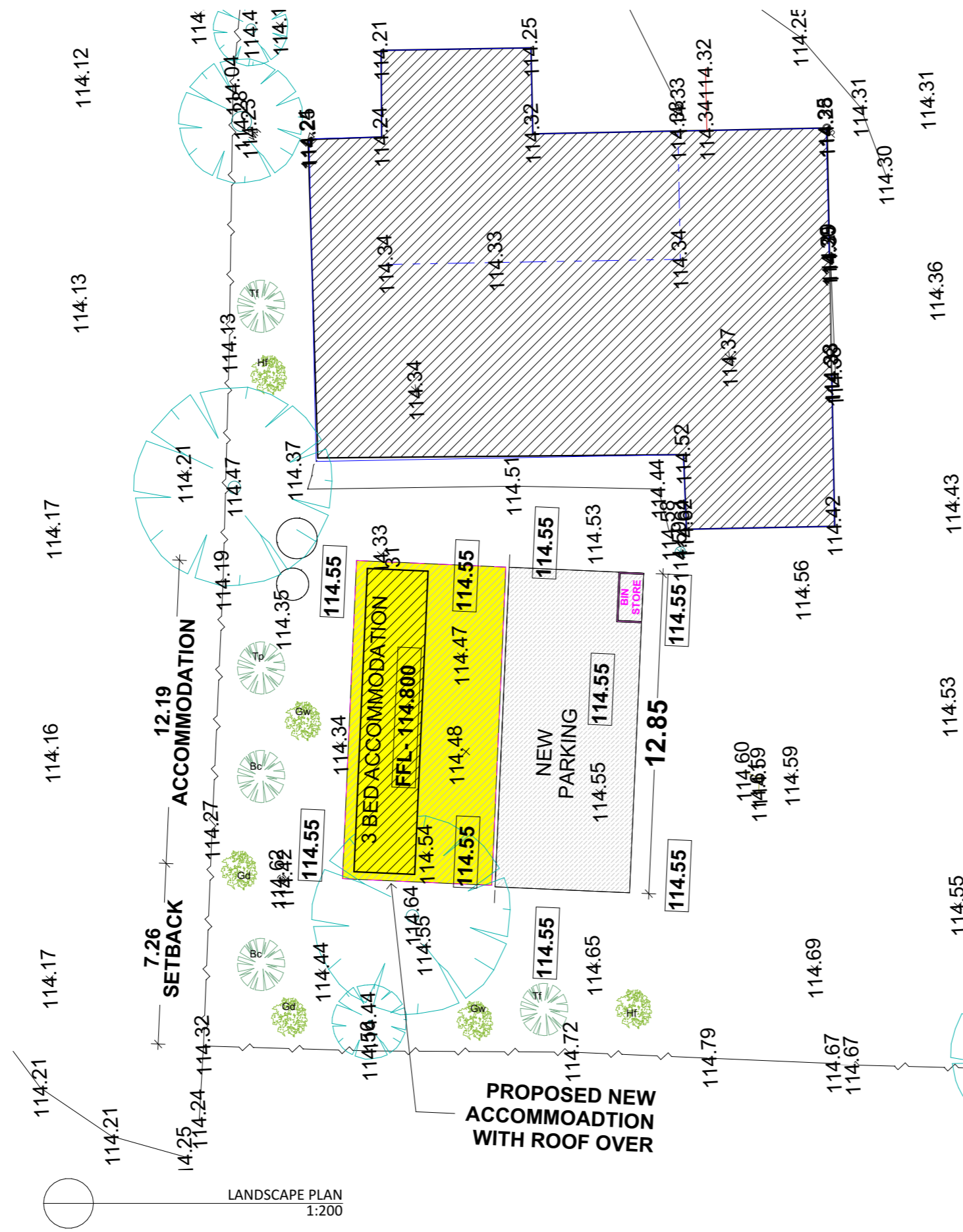

masika
design & consulting services
15 Ashley Ave. Quinns Rocks, WA. 6728
Mob: 0434 572057
paul@masikadesign.com.au



NATIVE PLANTING LEGEND

VARIETY	SIZE	QTY
TREES		
TF Terminalia Ferdinandiana, Gubinge or Kakadu Plum	1500mm	2
TP Terminalia petolaris, Marul Tree	1800mm	1
BC Bauhinia Cunninghamii, Jikily Tree	1500mm	2
SHRUBS		
Gd Grevillea dryandrii	175mm	2
Gw Grevillea wickhamii	175mm	2
HF Hakea Formosa	175mm	2

KEY DISCRPTION

 TREE
 SHRUB
 EXISTING TREE TO REMAIN

All Levels to shaped to allow water to flow away from buildings and to the road.
 Water Wise automatic irrigation system - overhead watering to turf areas, drip irrigation to all plants.
 Use locally available options to trees, shrubs specified.

GENERAL NOTES:

- ALL DRAWINGS SHALL BE READ IN CONJUNCTION WITH ALL OTHER CONSULTANTS DRAWINGS AND SPECIFICATIONS.
- REFER ANY DISCREPANCIES TO ARCHITECT BEFORE PROCEEDING WITH THE WORK.
- FIGURED DIMENSIONS SHALL TAKE PRECEDENCE OVER SCALED MEASUREMENTS.
- CHECK AND CONFIRM EXISTING LEVELS AND DIMENSIONS ON SITE PRIOR TO THE COMMENCEMENT OF ANY WORK.
- THIS DRAWING IS PROTECTED BY AUSTRALIAN AND INTERNATIONAL COPYRIGHT LAW.
- EXISTING PLAN HAS BEEN DRAWN FROM SURVEY INFORMATION PROVIDED.
- EXISTING SERVICES POINTS TO BE VERIFIED ON-SITE - LOCATIONS SHOWN ON THESE PLANS ARE INDICATIVE ONLY DO NOT SCALE DIMENSIONS FROM DRAWINGS.

REV	NOTE	DATE
A	DEVELOPMENT APPLICATION	01-09-2025
B	DEVELOPMENT APPLICATION REV-01	19-11-2025
C	DEVELOPMENT APPLICATION REV-02	10-12-2025
D	ROOF AND SLAB ENGINEERING	03-02-2026
E	DEVELOPMENT APPLICATION REV-03	11-02-2026

LAYOUT TITLE:
LANDSCAPE PLAN

PROJECT STATUS:
 DEVELOPMENT APPLICATION REV-03

SCALE:
 1:200 @ A3

DRAWN BY:
 PG

PROJECT/CLIENT:
PROJECT NAME
203 EMANUEL WAY FITZROY
CROSSING WA 6765
 LEAMY CONSTRUCTIONS

PROJECT NO:
 M25-429

DRAWING NO:
A1-04

West Elevation

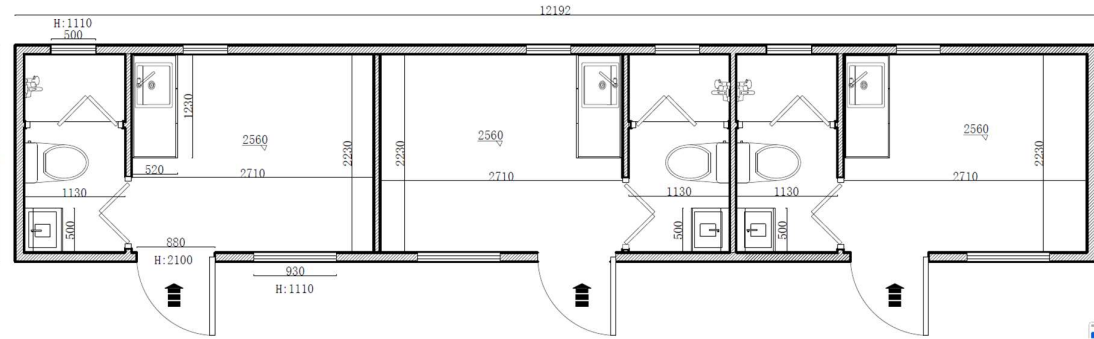

South Elevation

East Elevation

North Elevation

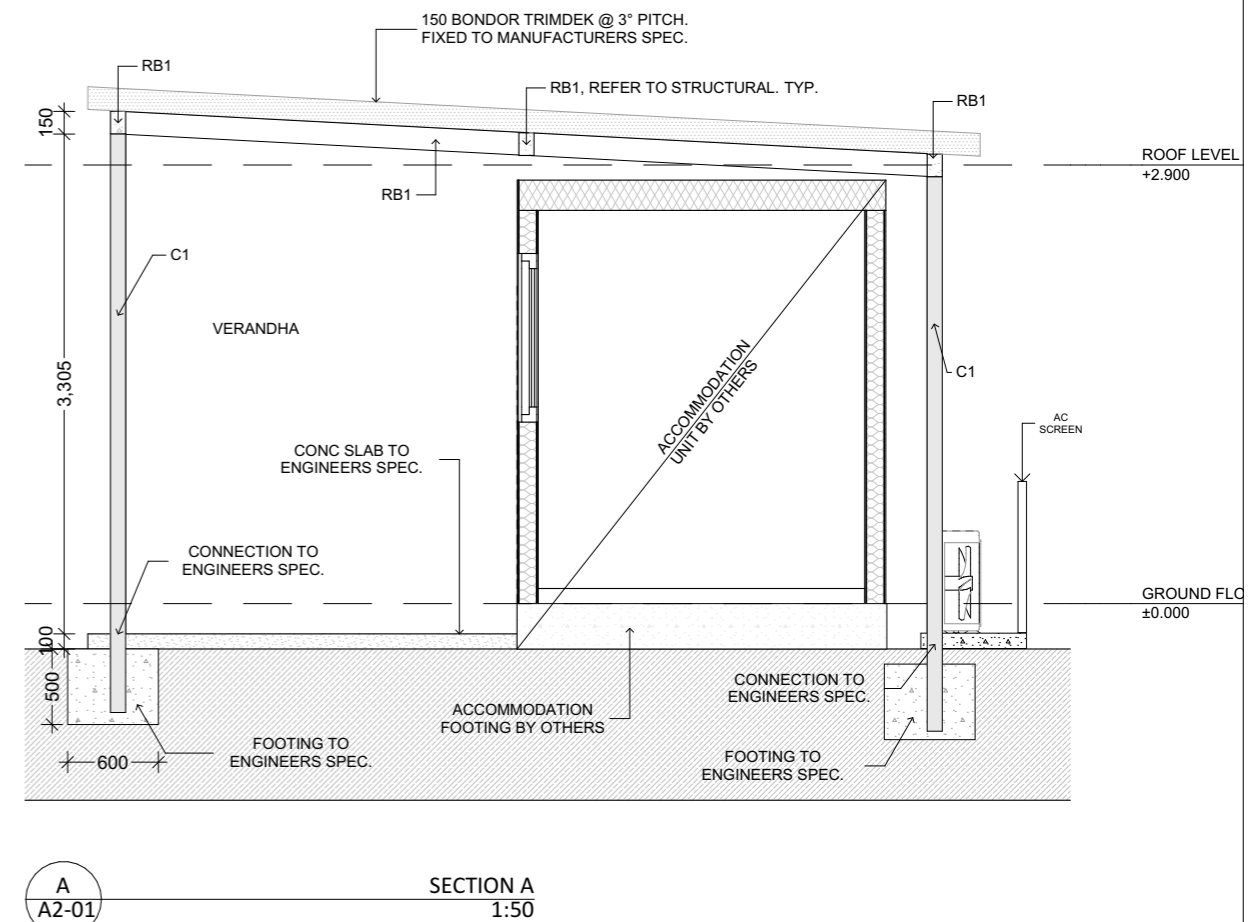
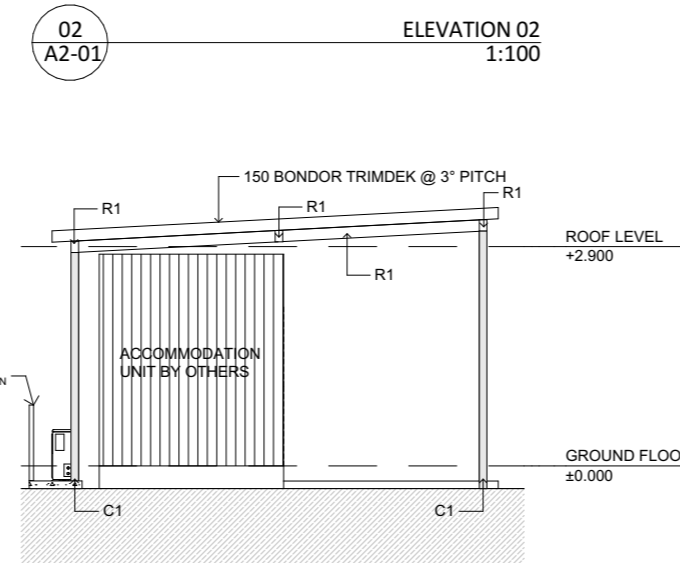
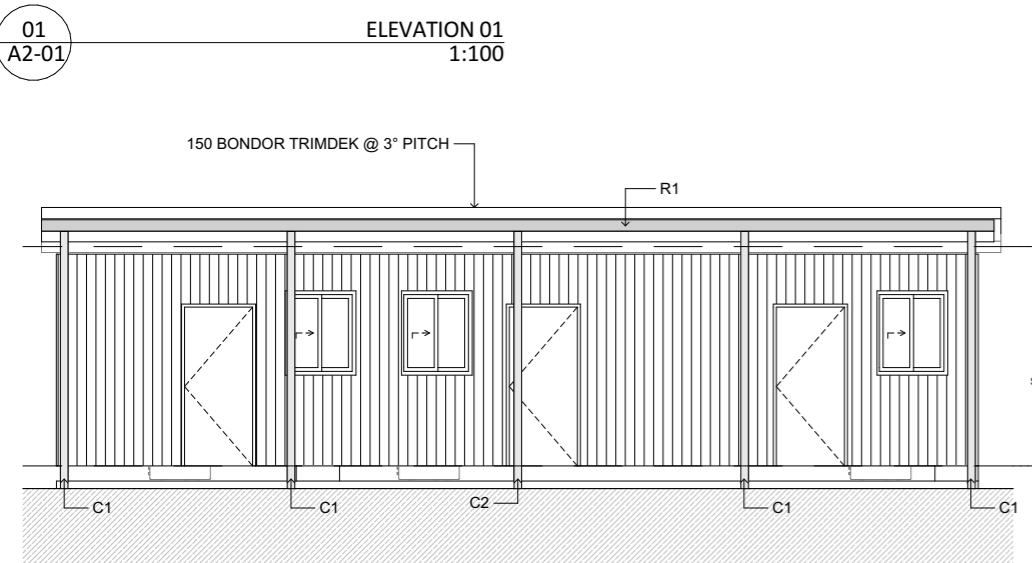
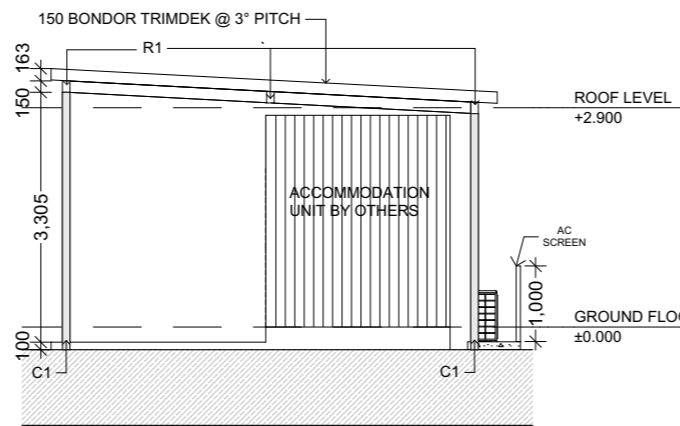
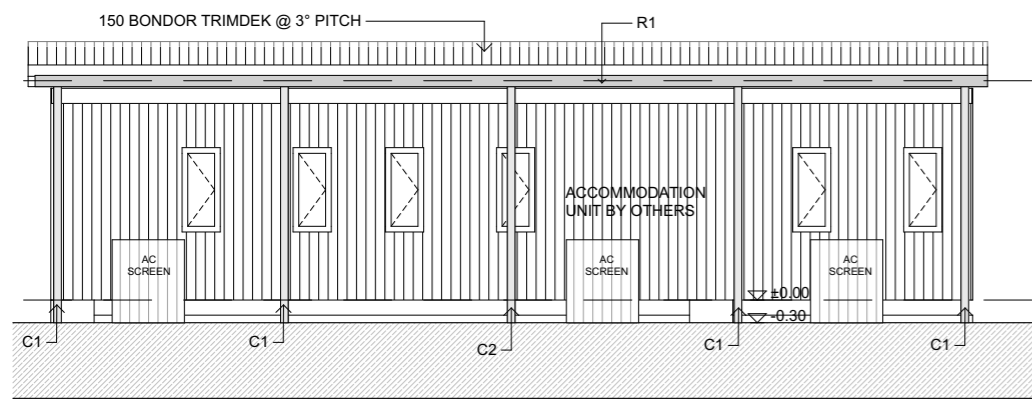
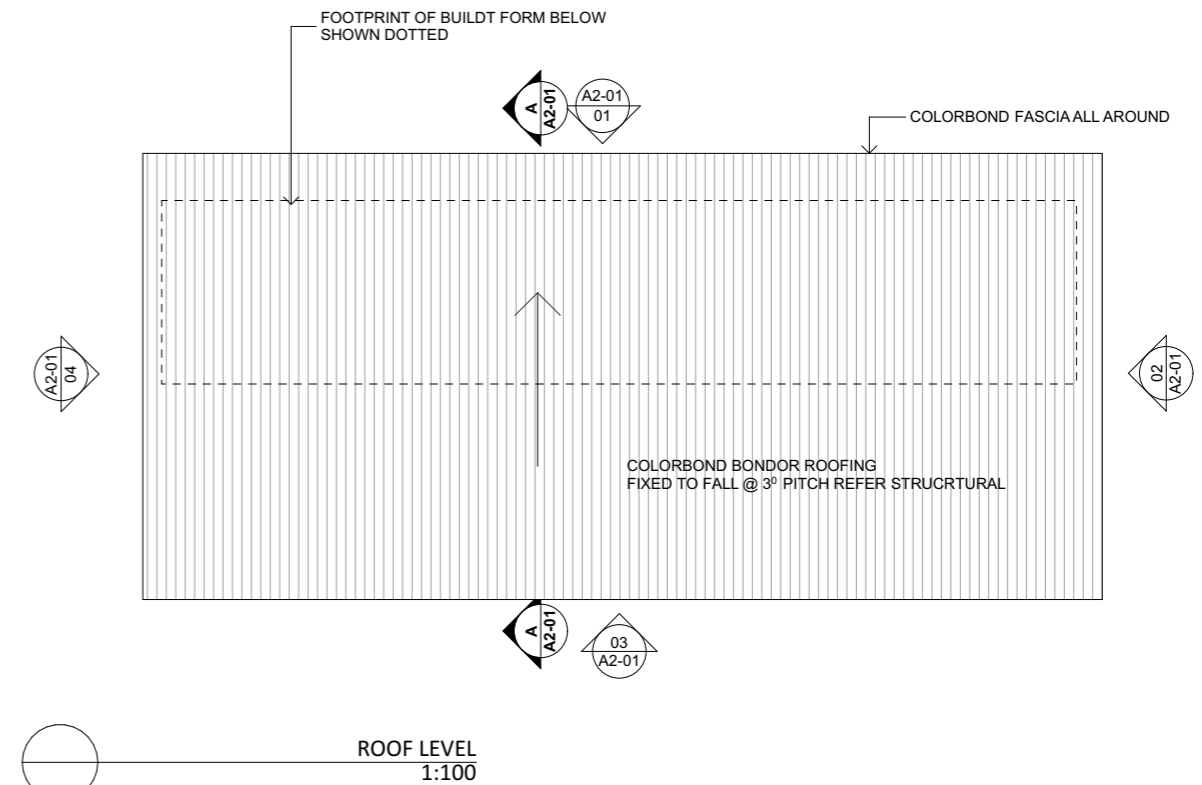
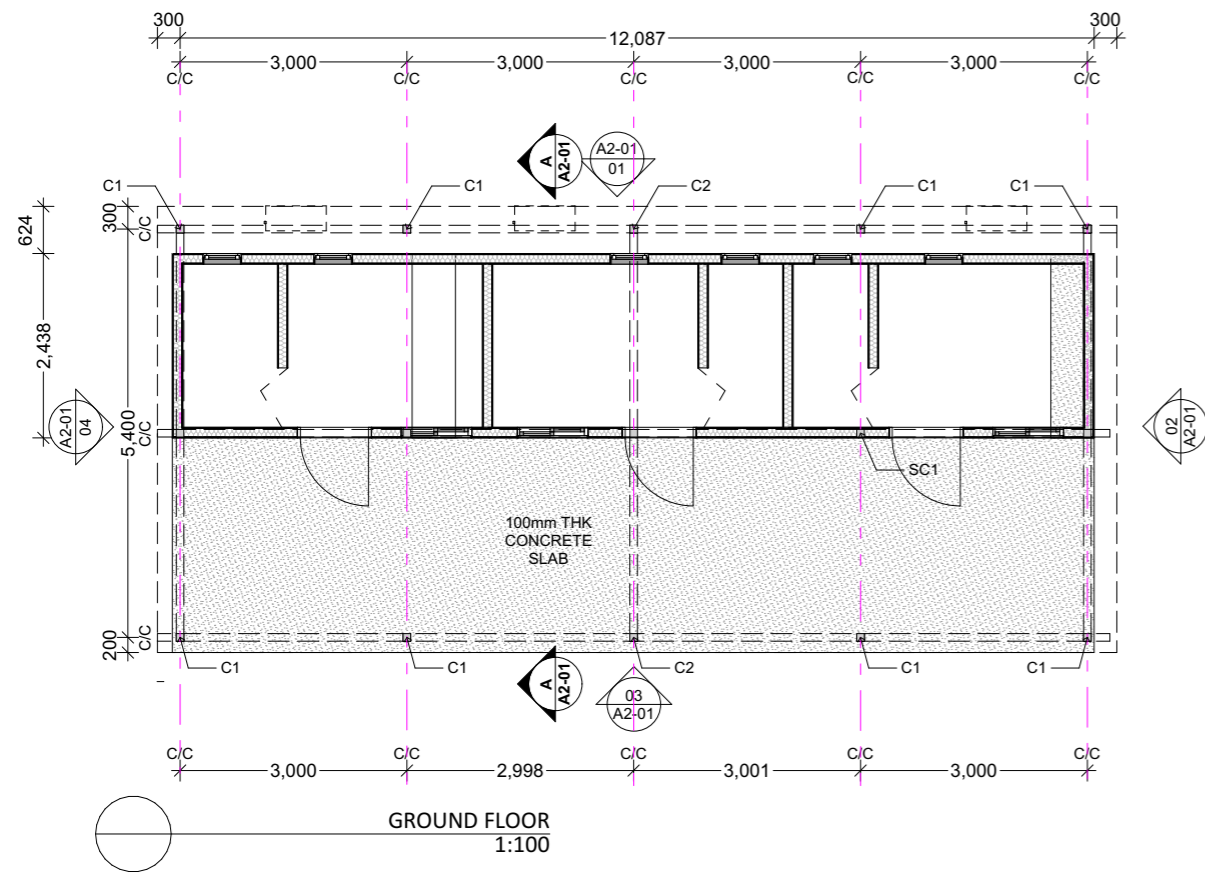

- GENERAL NOTES:
- ALL DRAWINGS SHALL BE READ IN CONJUNCTION WITH ALL OTHER CONSULTANTS DRAWINGS AND SPECIFICATIONS.
 - REFER ANY DISCREPANCIES TO ARCHITECT BEFORE PROCEEDING WITH THE WORK.
 - FIGURED DIMENSIONS SHALL TAKE PRECEDENCE OVER SCALED MEASUREMENTS.
 - CHECK AND CONFIRM EXISTING LEVELS AND DIMENSIONS ON SITE PRIOR TO THE COMMENCEMENT OF ANY WORK.
 - THIS DRAWING IS PROTECTED BY AUSTRALIAN AND INTERNATIONAL COPYRIGHT LAW.
 - EXISTING PLAN HAS BEEN DRAWN FROM SURVEY INFORMATION PROVIDED.
 - EXISTING SERVICES POINTS TO BE VERIFIED ON-SITE - LOCATIONS SHOWN ON THESE PLANS ARE INDICATIVE ONLY DO NOT SCALE DIMENSIONS FROM DRAWINGS.

REV	NOTE	DATE
A	DEVELOPMENT APPLICATION	01-09-2025
B	DEVELOPMENT APPLICATION REV-01	19-11-2025
C	DEVELOPMENT APPLICATION REV-02	10-12-2025
D	ROOF AND SLAB ENGINEERING	03-02-2026
E	DEVELOPMENT APPLICATION REV-03	11-02-2026

LAYOUT TITLE:
GROUND FLOOR & ROOF PLAN

PROJECT STATUS:
DEVELOPMENT APPLICATION REV-03

SCALE:
1:100 @ A3

DRAWN BY:
PG

PROJECT CLIENT:
PROJECT NAME
203 EMANUEL WAY FITZROY
CROSSING WA 6765
LEAMY CONSTRUCTIONS

PROJECT NO:
M25-429

DRAWING NO:
A2-01